

一盅搅粉机

1PC fask vacuum mixer

M.VM.SAS01B



It is recommended to first check the powder roasting operation process in the "Yihui Product Catalog".

Step 1: According to the ratio of water and powder, weigh the investment powder and the required water (300-400ml water for 1kg powder)

Step 2: Place the flask with the wax mold in the center position on the bottom plate and check whether it is aligned with the powder outlet.

Step 3: Pour water and gypsum powder into the Mixing barrel in sequence.

Step 4: Turn on the "mixing switch" on the operation panel and turn the timer to set the mixing time.

Step 5: Turn on the "vacuum switch" and turn on the vacuum pump (vacuum while mixing)), and do not stop vacuuming.

Step 6: Wait for the mixing time to end, pull open the "powder ball handle" valve, be careful not to overflow the flask when adding powder, and do not add powder too quickly to avoid damaging the wax mold.

Step 7: Stop mixing, continue to vacuum, and turn on the vibration switch. After the flask is filled, close the "powder ball handle" valve.

Step 8: Observe the condition of the gypsum powder in the flask, and turn off vibration, vacuum and exhaust in sequence.

Step 9: Take out the flask and clean the upper and lower barrels.

Tip: Clean the upper and lower barrels immediately after each operation to prevent the plaster from solidifying and damaging the equipment.

五、维护及保养 Maintenance

使用后及时清理干净

Please clean up immediately after use.

声明

致用户：

为安全操作并最大限度发挥本机性能，请在操作前仔细阅读说明书，并严格遵守安全规则，以防发生意外事故，造成不必要的损失。

在机器使用的过程中，如遇到问题可以随时联系本公司销售人员，我们将会竭诚为您服务。

在保修期间，如果未经本公司允许，用户不得擅自拆开机器进行错误的检修，如擅自

拆开机器，保修期将自动失效，不再享受本公司保修服务。

机器使用时所产生损失、利益损失和各种违规操作造成的各种间接损害，概与本公司无关。

未经本公司许可，产品说明书的所有内容，不得以任何形式翻版、传播、转载。

说明书因修改而进行的变更，恕不另外通知。如果您发现任何错误或遗漏，请您所购买的供应商反馈，对此，我们深表感谢。

STATEMENT

To users:

We are greatly appreciated for the support and trust you give to us. To ensure safe operation and play the property of this machine in full, please read the user manual in advance and observe the safty rules in case that accidents happen and unnecessary loss incurs.

If you meet any problem when using this machine, please feel free to contact our salespersons. We will try our best to give you service.

We are not responsible for the loss including loss in interest and all indirect damages caused by operations due to rule-breaking operations.

Without our permission, it is prohibited to copy, disseminate or reprint the whole content of this user manual in any form.

This manual is subject to alterations without prior notice. If you find any mistake or omission in this manual, please inform the supplier you mistake or omission in this manual, please inform the supplier you bought the machine from. We will be very grateful for this.

一、概述 Summary

本机主要功能为石膏粉搅拌及钢盅注粉。其体积小，一次最大放置4"×8"钢盅一个，更适应于工作室使用，其操作灵活，集搅拌、震动、抽真空等功能，便捷可靠。为了防止由于不熟练而造成的人身伤害、机器损坏及材料浪费等，因此，在使用本机前，操作人员必须经过培训并充分理解机器的构成及注意事项，且仔细阅读使用说明书。

The main function of the machine is for mixing gypsum and injecting powder to fasks. The volume is small and it support max 1PC Φ4"x H8" fasks at a time, and more suitable for studio. The operation is flexible, integrating functions such as stirring, vibration, and vacuuming which is convenient and reliable. In order to avoid personal injury, machine damage and material waste caused by unskillful person, the operator must be trained and well know the composition and precautions of machine before operate machine, and read the instruction carefully.

在机器使用的过程中，如遇到问题可随时联系本公司销售人员，我们将会竭诚为您服务。

在保修期间，未经本公司许可，用户不得擅自拆开机器进行错误的检修，如擅自拆开机器，保修期将自动失效，不再享受本公司保修服务。

说明书因修改而进行的变更，恕不另行通知。如果您发现任何错误或遗漏，请您向所购买的供应商反映，对此，我们深表感谢。

In the process for using the machine, if you have any problems, please feel free to contact our sales staff, we will be pleased to serve you.

During the warranty period, if without the permission of our company, the user is not allow to disassemble the machine for wrong maintenance. If the machine is disassembled without authorization, the warranty period will be automatically invalidated and the company's warranty service will be terminated.

The instructions are subject to change without prior notice. If you find any errors or omissions, please report it to the supplier you purchased, and we appreciate it.

二、机器构成 Instruction of machine

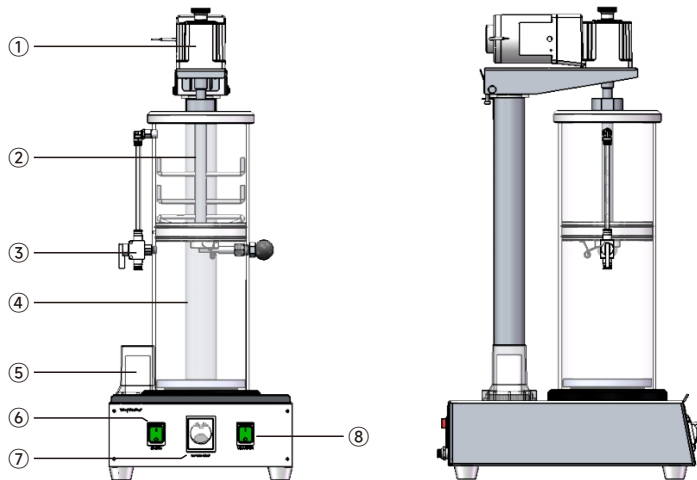

- | | |
|------------------|--|
| ① 搅拌电机 | ① Motor |
| ② 石膏搅拌室 | ② Mixing barrel |
| ③ 抽真空(向上)/排气(向下) | ③ Vacuuming switch (up)/Exhausting switch (down) |
| ④ 真空钢盅室 | ④ Vacuum flask barrel |
| ⑤ 真空过滤器 | ⑤ Vacuum filter |
| ⑥ 搅拌开关 | ⑥ Mixing switch |
| ⑦ 搅拌时间 | ⑦ Mixing timer |
| ⑧ 震动开关 | ⑧ Vibration switch |

注：“垫板”为选配件，若放置4"×8"钢盅，则不需要垫板
Remark: "Base plate" is an optional part. If it is a 4"x10" flask, you don't need a base plate; if it is a smaller size flask, you can choose a base plate.

三、产品技术参数 Parameters

型号: Z.M.VM.SAS01	Model: Z.M.VM.SAS01
电压: 220V	Voltage: 220V
功率: 60W	Power: 60W
抽气速率: 4L/S	Pumping rate: 4L/S
搅拌速度: 150rpm/min	Mixing speed: 150rpm/min
尺寸: 405x300x761mm	Size: 405x300x761mm
重量: 24.5kg	Weight: 24.5kg

四、操作说明 Operational approach

建议先查看“艺辉产品册”上的开粉焙烧操作流程。

第1步：根据石膏粉的特性，按“粉水比例”称好所需的水和石膏粉。

第2步：将装好蜡模的钢盅居中位置，置入在底盘上，检查是否对准下粉口。

第3步：依次将水和石膏粉倒入石膏搅拌室。

第4步：启动操作面板上的“搅粉”开关，旋钮定搅拌时间。

第5步：打开“真空”手柄开关置上状态，开启真空泵（可以边搅边抽真空），抽真空不要停。

第6步：等待搅拌时间结束，拉开“下粉球柄”阀门，下粉注意不要溢出钢盅，下粉速度也不要太快，避免冲坏蜡模。

第7步：停止搅拌，继续抽真空，并打开震动开关，钢盅浇灌满后，关闭“下粉球柄”阀门。

第8步：观察钢盅石膏情况，依次关闭震动 - 真空 - 排气。

第9步：取出钢盅，并清洗上下桶。

提示：每次操作完成后立刻将上下桶清洗干净，以免石膏凝固，损坏设备。